

The Need For Every  
Process Industry

**SPINK CONTROLS**®

An ISO 9001:2015 Certified Company



**THERMOWELL**

**MODEL: SC / T - 01 / TW**

**TEMPERATURE**

# THERMOWELL

MODEL: SC / T - 01 / TW



A thermowell is a pressure-tight metallic fitting used to protect temperature sensors such as RTDs and thermocouples from harsh process conditions including high pressure, velocity, corrosion, and mechanical stresses. Installed directly in pipelines or vessels, it allows safe sensor removal or replacement without process shutdown, ensuring reliable and long-term temperature measurement across chemical, petrochemical, power, oil & gas, fertilizer, and other process industries.

## CONSTRUCTION

Thermowells are manufactured from solid bar stock or pipe construction, precision machined to ensure high strength and dimensional accuracy. The design consists of a process connection, shank, and sensor bore, engineered to withstand process pressure, temperature, and flow-induced stresses. Available in straight, tapered, stepped, and twisted shank designs, the construction ensures optimal heat transfer, mechanical integrity, and long service life.

### THREADED



### FLANGED



### WELDED



### SANITARY



## DRAWING

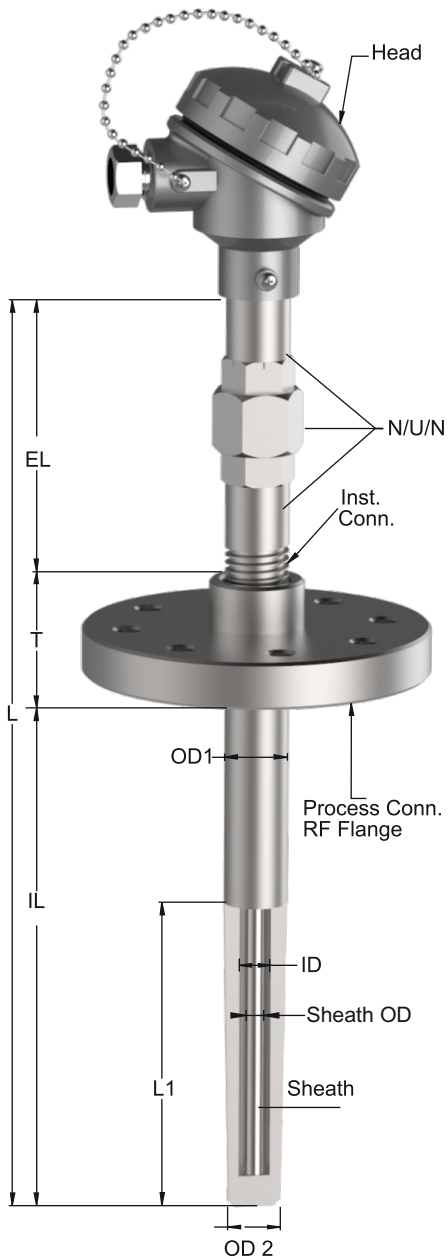

## ENGINEERING SPECIFICATION

MANUFACTURING TYPE	: AR STOCK MACHINED / PIPE FABRICATED
MOUNTING TYPE	: FLANGED / THREADED / WELD-IN / VAN STONE
SHANK DESIGN	: STRAIGHT / TAPERED / STEPPED / TWISTED TYPE THERMOWELL
INSERTION LENGTH (U)	: AS SPECIFIED
PROCESS CONNECTION	: 1/2" TO 3"   ANSI 150# TO 1500# (OTHER ON REQUEST)
TEMPERATURE RANGE	: UP TO 600 °C (HIGHER ON REQUEST)
FLOW VELOCITY	: DESIGNED AS PER WAKE FREQUENCY & STRESS LIMITS
MATERIAL	: SS316, SS304, INCONEL, TITANIUM, NICKEL, MONEL, (OTHER ON REQUEST)



### Head Office

303, SIDDHARTH TOWER, G.P. PAI ROAD, KOPRI, THANE (E) - 400603 MAHARASHTRA, INDIA  
 Phone : +91 22 2532 8223  
 +91 22 2532 8224  
 Email : info@spinkcontrolsindia.com

### Plant 1

GALA No. F-4 A WING, UDYOG BHAVAN-2 ADDITIONAL AMBERNATH, INDUSTRIAL AREA, ANAND NAGAR MIDC AMBERNATH, THANE 421501  
 Phone : +91 9594991196  
 Email : rupa.thakkar@spinkcontrols.com

### Plant 2

PLOT No.: MS 114/115, AMBERNATH INDUSTRIAL AREA, CHIKHLOLI MIDC, AMBERNATH (W) THANE 421501  
 Phone : +91 7400159593  
 Email : avanti.rangdal@spinkcontrols.com

